



COCHIN PORT TRUST
MARINE DEPARTMENT

E- TENDER No.MD/PMW/ GHDNS GRAB REPAIRS /2020-22 dated 02-06-2020

Tender Document

“Rate Contract for Repairs of Grabs of GHD Nehru Shatabdi for Two years”

Tender publication date	: 3 rd June 2020
Down loading of Tender Document	: From 3 rd June 2020, 1700 hours to 24 th June 2020, 1400 hrs
Last date and time for Submission of Tenders:	: 24 th June 2020, 1430 hours
Time and date of technical bid opening	: 24 th June, 2020, 1500 hours
Opening Of The Price Bid	: Will be informed later
Cost of Tender Document / Processing Fee (Tender fee is inclusive of 5% GST)	: Rs.3150/- (non refundable)
EMD	: Rs.32305/-
E-Tendering portal	: www.Tenderwizard.com/CPT

Office of the Deputy Conservator
Cochin Port Trust,

Cochin – 682 009.

Phone: 91 484 2666417, 2582500,2582521,2582377

Fax: 91 484 2666417

e-mail: dc@cochinport.gov.in

bhagavathsing@cochinport.gov.in

Contents

1.Section I Tender Notice.....	3
2.Section II Instructions to Tenderer	7
3.Section III General Conditions of Contract.....	10
4.Section IV Special Conditions & Scope of Work	15
5.Annexure I Drawings and Part numbers	18
6.Schedule A List of documents to be submitted in TC bid.....	30
7.Price Schedule B1	29
8.Price schedule B2.....	32
9.Schedule C Details of Financial Stability.....	35
10.Schedule D Structure of Organisation.....	36
11.Schedule E Details of Experience.....	37
12 Annexure I Performa for undertaking that No changes has been made in the downloaded document.....	38
13.Annexure II Performa for undertaking regarding Illegal Method For Influencing Tender process.....	39
14.AnnexureIII Performa of disclosure of payment.....	40.
15.Form I Form of Bank Guarantee.....	41
16.Form II Proforma of Agreement	43

Section 1. E-TENDER NOTICE

E- TENDER No.MD/PMW/ GHDNS GRAB REPAIRS /2020-22 dated 02-06-2020

“Rate Contract for Repairs of Grabs of GHD Nehru Shatabdi for Two years

- 1.1. Electronic tenders (e-tenders) in two cover system are invited by the Dy. Conservator, Cochin Port Trust, Willingdon Island, Cochin 682009 for “Rate Contract for Repairs of Grabs of GHD Nehru Shatabdi for Two years”
- 1.2. Tender documents can be downloaded from the e-tendering portal www.tenderwizard.com/CPT or from CoPT website www.cochinport.gov.in or from Central Public Procurement Portal www.eprocure.gov.in/cppp
- 1.3. The bidders should have a valid digital signature certificate (Class-II or Class-III) issued by any of the valid Certifying Authorities to participate in the online tender.
- 1.4. The bids should be uploaded in electronic form only through e-tender portal www.tenderwizard.com/CPT.
- 1.5. Cost of tender document **Rs. 3150/-** including GST and Earnest Money Deposit (EMD) **Rs.32305/-**(Exempted for tenderers with valid NSIC Registration Certificate as per MSME Act –certificate to be uploaded online), including GST are to be remitted in the form of the Banker’s Cheque or DD issued by Nationalized / Scheduled banks, drawn in favour of FA & CAO, Cochin Port Trust, payable at Cochin as two separate DD/Bankers's Cheque.
- 1.6. The Original EMD and Tender Document fee drawn in favour of the FA & CAO, Cochin Port Trust, payable at Kochi shall be submitted in Sealed envelope with a covering letter and shall be addressed to the Dy. Conservator, Cochin Port Trust, Cochin 682 009, and shall be super scribed with words “**Rate Contract for Repairs of Grabs of GHD Nehru Shatabdi for Two years**”, before the scheduled date and time of opening of the bid, failing which the bid will be rejected. EMD in any form other than the DD/Bankers cheque will not be accepted.
- 1.7. The Tenderers who are registered with NSIC are exempted from payment of cost of Tender Document and EMD. Copy of valid NSIC Registration Certificate as per MSME Act shall be uploaded with the other documents for availing exemption of the above. The Tenderers who have not submitted the cost of Tender Document and EMD in sealed covers and not uploaded the scanned copy of valid NSIC Registration Certificate will not be considered for opening Techno Commercial Bids. **(The fees mentioned above are the only item to be submitted in original to CoPT before the scheduled time for participating in the Tender. All other Documents to be submitted online only).**
- 1.8. Scanned copy of DD/Bankers's Cheque towards Cost of Tender Document and EMD (as mentioned in clause 1.5 above) shall also be uploaded in the e-tender portal www.tenderwizard.com/CPT, failing which the bid will be rejected.
- 1.9. The bidders need to obtain one time User ID & password for log-in to e-Tendering portal www.tenderwizard.com/CPT from the service provider KEONICS, by paying

Cochin Port Trust
TENDER No.MD/PMW/ GHDNS GRAB REPAIRS /2020-22

their registration amount through online Payment using Credit/Debit Card/Net banking or DD in favour of “KSEDCL, Bangalore”. The details of e-tender facilitator is available through Telephone Nos. **080 49352000/ 09605557738**.

- 1.10. The tenders shall be submitted “**on line**” strictly in accordance with the Instructions to Tenderers and other terms & Conditions given in the tender document.
- 1.11. The bidders shall submit scanned copy of all the required documents such as proof of experience, financial details, etc. in the e-tender portal www.tenderwizard.com/CPT.
- 1.12. Time schedule for various activities in connection with this tender will be as follows:

Sl. No	Description of activity	Venue	Time
1	Issue of Tender Document	On line www.Tenderwizard.com/CPT www.cochinport.gov.in www.eprocure.gov.in/cppp	From 3 rd June 2020, 1700 hours to 24 th June 2020, 1400 hours
2	Last date of submission of bid	Online Submission at: www.Tenderwizard.com/CPT	24 th June 2020, 14.30 hours
3	Opening of Techno commercial bid	Online at: www.Tenderwizard.com/CPT	24 th June 2020, 1500 hours
4	Opening of Price Bid of technically qualified Tenders	Online at: www.Tenderwizard.com/CPT	Will be informed

- 1.13. The Tender shall be submitted by an individual or by a Registered Partnership firm or by a Limited Company. **The name and address of the Tenderer shall be entered in the space provided in ‘Price Bid’**. In the event of the Tender being submitted by a registered partnership firm, it must be signed individually by each partner thereof. In the event of absence of any partner, it must be signed on his behalf by the person holding a proper power-of-attorney, authorizing him to do so and to bind all the partners in all matters pertaining to the contract including the arbitration clause, such power-of-attorney to be attached with the Tender which must disclose that the firm is duly registered under Indian Partnership Act. If the Tender is made by a Limited Company it shall be signed by a duly authorized person who shall produce with the Tender the evidence of the authorization. In the case of a Limited Company the Tender should be accompanied by the Memorandum and Articles of Association of the Company. **Joint Venture is not allowed in the Tender.**

Cochin Port Trust
TENDER No.MD/PMW/ GHDNS GRAB REPAIRS /2020-22

1.14. Preparation and submission of bids.

The Documents shall be prepared and scanned in different files (in PDF or JPEG format such that file size is not more than 5 MB) and uploaded during the online submission of Bid at www.Tenderwizard.com/CPT.

- 1.15. The right of acceptance of Tender will rest with Cochin Port Trust who do not bind themselves to accept the lowest Tender and reserves to themselves the authority to reject any or all of the Tenders received without assigning any reason thereof.
- 1.16. The Tender Document will be available in the e-Tendering Portal. All the schedules in the content sheet should be filled up **except price bid**. The price schedule should be kept blank. All the pages of the Tender Documents including Price Bid (**not filled**) shall be signed by the contractor.
- 1.17. The Deputy Conservator or his duly authorized officer will open the E-Tenders online in the presence of intending Tenderers who may be present at the time in person or through their authorized representative. In the event of a Tender being rejected, the earnest money paid with such unaccepted Tender shall be refunded to the Tenderer.
- 1.18. It is obligatory on the part of the Tenderer to sign each and every page of the of Tender Document as a token of acceptance of all the conditions mentioned in the Document, while submitting the Tender online.
- 1.19. The Tender shall remain valid and open for acceptance for a period of 90 days from the last date fixed for receiving the same. The Employer reserves the right to extend the period of validity for a specific period. The request and response thereto shall be made in writing by post or by fax or by email. The Tenderers will have an option to refuse the request without forfeiting their EMD. However in the event of the tenderer agreeing to the request, they will not be permitted to modify the Tender.
- 1.20. Should any tenderer withdraw his Tender before the period, or make any modification in the terms and conditions of the Tender which are not acceptable to the department and the earnest money deposited by the Tenderer shall be forfeited.
- 1.21. Tenderers should send **a letter of authorization** with an attested specimen signature of their representatives who are deputed by them to be present at the time of opening of the Tenders.
- 1.22. Tenders, which do not fulfill all, or any of the above conditions, or are incomplete in any respect, are liable for summary rejection at any stage before placement of order.
- 1.23. Canvassing in connection with the Tender is strictly prohibited and Tenders submitted by the contractors who resort to canvassing will be liable for rejection.
- 1.24. The under signed reserves the right to reject / cancel / postpone any one or all Tenders at any stage of the Tender, which will be binding on all bidders.
- 1.25. The Tenders containing uncalled remarks or any additional conditions are liable to summary rejection.
- 1.26. Disputes if any shall be under the jurisdiction of courts in Cochin Corporation limits only.

Cochin Port Trust
TENDER No.MD/PMW/ GHDNS GRAB REPAIRS /2020-22

1.27. This Tender notice shall form part of the contract.

1.28. **All Tenderers are advised to visit CoPT and inspect any of the Grabs before submitting their offer in order to make themselves fully aware of the nature of work.** Cochin Port Trust will not be responsible for any cost or expenses incurred by the Tenderer in connection with the preparation or delivery of the tenders including cost and expenses related to visits to the sites.

Sd/-

Phone : 0484-2666417
 : 0484-2582500
Fax: 0484-2666417

Deputy Conservator
For and on behalf of
The Board of Trustees of the Port of
Cochin.

Section 11. INSTRUCTIONS TO TENDERER

- 2.1. **Scope of Tender:** Electronic Tenders (e-tenders) in two-cover system are invited from eligible Tenderers for the "Rate Contract for Repairs of Grabs of GHD Nehru Shatabdi for Two years". Tenders should be submitted in accordance with the Instructions to Tenderer, General Conditions of Contract, Special Conditions and the Scope of work etc as enumerated in this tender document.
- 2.2. **Availability of Tender Documents:** The Tender document can be downloaded from the e-tendering portal www.tenderwizard.com/CPT or from Port's website www.cochinport.gov.in or from Central Public Procurement Portal www.eprocure.gov.in/cppp
- 2.3. **Cost of tender document: Rs 3150/-** including GST, is to be remitted in the form of the Banker's Cheque (BC) or Demand Draft (DD) from a Scheduled / Nationalized bank having their branch in Cochin, drawn in favour of FA&CAO, Cochin Port Trust, payable at Cochin. Cost of tender document will not be refunded. Cost of tender document in the form of Cheque/ Bank Guarantee will not be accepted. Tenders without cost of tender document will not be accepted.
- 2.4. **EMD: Rs.32305/-** is to be remitted in the form of the BC/DD from a Scheduled / Nationalized bank having their branch in Cochin, drawn in favour of FA&CAO, Cochin Port Trust, payable at Cochin. Earnest money in the form of Cheque/ Bank Guarantee will not be accepted. Tenders without EMD will not be accepted.
 - 2.4.1. The Earnest Money Deposit of unsuccessful tenderers will be refunded on award of contract to the successful tenderer. The EMD of successful tenderer will be refunded on submission of security deposit and executing agreement.
 - 2.4.2. No interest will be paid on the Earnest Money Deposit from the date of its receipt until it is so refunded.
 - 2.4.3. **The EMD shall be forfeited under following circumstances:-**
 - 2.4.3.1. In the event of the tenderer withdrawing / modifying his tender before the expiry of tender validity of 90 days from the date of submission and opening.
 - 2.4.3.2. Failing to furnish security deposit within the stipulated time, upon award of contract or failing to enter into an agreement with Cochin Port Trust as required in the tender within the stipulated time or within such extended time granted by Cochin Port Trust, the tender shall be liable to be cancelled and EMD shall be forfeited.
 - 2.4.4. Upon submission of Security Deposit and signing of Agreement by the successful tenderer, the Cochin Port Trust will refund their EMD.
- 2.5. DDs/BCs in lieu of Cost of Tender Document and EMD have to be scanned and attached in the e-tender portal www.tenderwizard.com/CPT. Original DDs/BCs in lieu of Cost of Tender Document and EMD has to reach office of the Deputy Conservator, on or before the date and time fixed for opening of techno-commercial bid. **Tenders which do not satisfy this condition will be rejected.**
- 2.6. Downloaded document is to be printed in a clearly readable form in A4 size sheet. Printed tender document shall be duly filled, signed and stamped on all pages for submission. The downloaded tender documents if found tampered with by way of any deviation from the original document hosted on website, will result in disqualification. Duly filled, stamped and signed tender documents including **price schedule (price schedule BI&BII should be kept blank)** and other documents shall be prepared and scanned PDF or JPEG format such that file size is not more than 5 MB and uploaded in

Cochin Port Trust
TENDER No.MD/PMW/ GHDNS GRAB REPAIRS /2020-22

the e-tender portal www.tenderwizard.com/CPT. Any tender not so complete is liable to be rejected.

2.7. **PROVEN TRACK:** Tenderer should have experience in fabrication and repairs of steel structures/ machineries/equipments.

2.8. MINIMUM QUALIFICATION CRITERIA (MQC): Tenderer must fulfill the following minimum qualifying criteria to prove the techno-commercial competence and submit the documents in support thereof:

2.8.1. Firms shall have undertaken similar works ie. Steel Fabrication, repair, welding works, reconditioning of machinery/equipments in floating crafts/shipyards/ports/ power plants/petrochemical industries/process industries and any other reputed industries, during the last seven years ending **31.05.2020**, as follows:

2.8.1.1 Three numbers of completed contract works, each single contract costing not less than Rs.12.93 lakhs.

OR

2.8.1.2 Two numbers of completed contract works, each single contract costing not less than Rs.16.16 lakhs.

OR

2.8.1.3. One number of completed contract work costing not less than Rs.25.85 lakhs.

2.8.2. Copies of supply/work orders and respective work completion certificate from clients for proving MQC stated at clause 2.8.1 above should be submitted along with the tender.

2.8.3. **Average annual financial turnover** of the tenderer should not be less than Rs.9.7 lakhs during the last three (3) years, taken together ending 31st March 2019. The details shall be furnished in Schedule C. Copy of auditor's report along with balance sheets for the past three years (**ie16-17, 17-18&18-19**) should be enclosed along with the tender

Price bids of those tenderers, who comply with the above criteria, only shall be considered for opening.

2.9. **Validity of Tender:** The tender shall remain valid and open for acceptance for a period of 90 days from the last date fixed for receiving the same. The Cochin Port Trust may request the tenderers to extend the period of validity for a specific period. The request and response thereto shall be made in writing/e-mail. The tenderer will have an option to refuse the request without forfeiting their EMD. However in the event of the tenderer agreeing to the request, they will not be permitted to modify the tender.

2.10. **Amendment of Tender Document:** At any time prior to the deadline for the submission of Tenders, Cochin Port Trust, for any reason, whether at his own initiative or in response to query from prospective tenderers, may modify the Tender document by an amendment.

2.10.1. The amendment in the form of addendum will be published in the CoPT website.

2.10.2. Any amendments issued will be hosted in the website at least 5 days prior to the dates specified for submission of the tender. Tenderers shall verify if any such amendment / modifications have been issued in CoPT website before submitting their tender and shall take cognizance of amendments and include such amendments in their submission. In any case amendments/ modifications if any, shall be binding on the tenderer.

2.10.3. The Cochin Port Trust may at their discretion extend deadline for the submission of tenders to enable prospective tenderer to take the amendment into account while preparing the tender.

Cochin Port Trust
TENDER No.MD/PMW/ GHDNS GRAB REPAIRS /2020-22

- 2.11. The Tenderer is expected to examine all instructions, forms, terms, specifications etc. in the tender document. Failure to furnish all information or documentations required in the Tender documents may result in the rejection of Tender.
- 2.12. Power of attorney for the signatory of the tender and for carrying out the works when awarded should be enclosed along with the tender.
- 2.13. The tenderer should not submit their offer with any conditions / counter conditions anywhere in the tender document. The conditional tenders, if any, shall be considered as non-responsive and shall be summarily rejected.
- 2.14. All the documents submitted should be indexed and page numbered

2.15. Submission of Tender:

- 2.15.1. DD/Banker's cheque towards cost of tender document and EMD should be scanned and attached in the e-tender portal and original DD/Banker's cheque shall be submitted to the Deputy conservator, CoPT in a sealed cover on or before the due date and time fixed for tender opening.
- 2.15.2. The tender document should be submitted as **two separate files** in the e-tender Portal; Bid shall be submitted in two parts ie **Part - I: Techno commercial Bid** and **Part - II: Price Bid (Price schedule BI&BII)**
- 2.15.3. Part -I file consisting of following copies of documents :
 - 2.15.3.1. Tender documents duly filled including **blank price schedule BI&BII**, signed and stamped on all pages.
 - 2.15.3.2. Supply/ orders/work orders and completion certificates for proving MQC.
 - 2.15.3.3. Profit and loss statement, balance sheets and auditor's report / annual Report for the past 3 years as per clause no.2.8.3.
 - 2.15.3.4. GST registration certificate and PAN card.
 - 2.15.3.5. Power of Attorney in favour of person authorized to sign the tender document.
 - 2.15.3.6. Schedules A, C, D & E, and Annexure- I, II and III duly filled and signed.
- 2.15.4. The other file Part -II, the price bid format (**Price schedule BI&BII**) is given as separate file. **It should be filled ON LINE only** by the bidder.
- 2.15.5. The tenderers are required to submit both Technical bid & Price bid in '*e-tender*' mode only on www.tenderwizard.com/CPT before the due date and time fixed for opening of techno-commercial bid.
- 2.15.6. Disclosure/indication of the Price(s) in the Techno- Commercial Bid shall make the Tender disqualified and will be rejected.
- 2.15.7. Tenderer should quote one price only for each line item. Declaring price discrimination by showing optional/alternative model or manufacturer may lead to rejection of the complete offer.
- 2.15.8. Corrections if any should be duly attested by the signature(s) of the tenderer (s) with date.
- 2.15.9. Cochin Port Trust shall not provide any forms for getting any exemptions from payment of duties and taxes.
- 2.15.10. Before submitting the tender, the tenderer shall examine all the tender conditions and instructions etc. in the tender document. The tenderer shall visit the site and get himself acquainted with all necessary data concerning this tender for the purpose of making responsive offer.
- 2.15.11. **All Tenderers are advised to visit CoPT and inspect any of the Grabs before submitting their offer in order to make themselves fully aware of the nature of work. They shall also study the scope/nature of work before quoting. Any doubt regarding the specifications, scope or any other conditions, shall be discussed with the Engineer in charge of GHDNS/ MES /SE (M) TT, CoPT.**

2.16. Opening of Tenders:

- 2.16.1. Techno-commercial Bid will be opened at the above prescribed date and time in the e-tender portal www.tenderwizard.com/CPT. Tenderers can witness the tender opening either direct or by logging in to the e-tender portal at the date and time fixed for tender opening
- 2.16.2. Price Bid of those tenderers who are found qualified after evaluation of techno-commercial bid will be opened “**on-line**”. Date and time of opening of price-bid will be intimated to the qualified bidders. Qualified bidders can witness opening of Price – Bid either direct or by logging in to the e-tender portal at the date and time intimated for opening of Price –Bid.
- 2.16.3. To assist in the examination, evaluation and comparison of tenders, Cochin Port Trust may ask tenderer individually for clarification of their tender.
- 2.16.4. **Determination of Responsiveness:** The tender which does not satisfy the pre-qualification criteria shall summarily be rejected and shall not be considered for further evaluation. The Port will scrutinize the tenders to determine whether the tender is substantially responsive to the requirements of the tender documents. For the purpose of this clause, a substantially responsive tender is one which inter-alia confirms to all the terms and conditions of the tender documents without any deviation or reservation. A tender that, in relation to the cost estimate of the Port, is seriously unbalanced may be rejected as non-responsive.
- 2.16.5. Canvassing in connection with the tender is strictly prohibited and the tenders submitted by the suppliers who resort to canvassing will be liable for rejection.
- 2.16.6. **Evaluation and comparison of tenders:** Only such tenders, as determined to be substantially responsive to the requirements of the tender documents will be evaluated. Other non- responsive tenders will be rejected. The Port's decision on this shall be final, conclusive and binding. **The price comparison and evaluation of tenders will be done based on the GRAND TOTAL amount quoted in the price schedules B1&B2 together, excluding GST**
- 2.16.7. **Acceptance of Tender:** Cochin Port Trust does not bind itself to accept the lowest tender or any tender and reserves the right to accept any tender in part or to reject any tender or all tenders without assigning any reasons whatsoever.
- 2.16.8. **Language of the tender:** The tender submitted by the tenderer and all correspondence and documents relating to the tender exchanged by the tenderer and the Cochin Port Trust shall be in **English language**. Any printed literature, other than in English language shall be accompanied by an English translation, in which case, for purpose of interpretation of the tender, the English translation shall govern.

SECTION III. GENERAL CONDITIONS OF TENDER

- 3.1. **DEFINITIONS:** In the Contract (as hereinafter defined) the definition of the following words and expressions shall have the meanings hereby assigned to them except where the context otherwise requires:
 - 3.1.1. "Employer" means Board of Trustees of Cochin Port, a body corporate under the Major Port Trust Act.1963, by notification issued by the Government of India, acting through its Chairman, Dy. Chairman or Deputy Conservator or any other officers so nominated by the Board.

Cochin Port Trust
TENDER No.MD/PMW/ GHDNS GRAB REPAIRS /2020-22

- 3.1.2. "Contractor" means the person or persons, firm, corporation or company whose tender has been accepted by the Employer and includes the Contractor's servants, agents and workers, personal representatives, successors and permitted assigns.
- 3.1.3. "Contract" means and includes Tender Documents, Instructions to Tenderers, General Conditions of Contract, Drawings, Specifications, and Schedules etc., any amendments thereto, Bid, Letter of Acceptance and the Contract Agreement.
- 3.1.4. "Contract Price" means the sum of amount arrived at by multiplying rate of each line item in the price schedule B1&B2 by the quantity of corresponding line item without GST. GST as per the prevailing rates will be paid by CoPT additional.
- 3.1.5. "Specifications" means the specification referred to in the tender documents if any and any modifications thereof or additions thereto or amendments thereto as may be from time to time be furnished or approved in writing by the Employer.
- 3.1.6. "Deputy Conservator" shall mean the Deputy Conservator of Cochin Port Trust and includes any officer who is authorized on his behalf for the purpose of this contract.
- 3.1.7. "Work" or "Works" shall mean the whole of the plant and materials to be provided and work to be done executed or carried out by the contractor under the contract.
- 3.1.8. The "Site" shall mean the whole of the premises, buildings, vessels and grounds of CoPT in or upon which the system or works is or are to be provided, executed, erected, done or carried out.
- 3.1.9. The "Schedule" shall mean the schedule or Schedules attached to the specifications if any.
- 3.1.10. The "Drawings" shall mean the drawings, issued with the specification which will ordinarily be identified by being signed by the Deputy Conservator and any further drawing submitted by the contractor with his tender and duly signed by him and accepted or approved by the Deputy Conservator and all other drawings supplied or furnished by the contractors or by the Deputy Conservator in accordance with these contract conditions.
- 3.1.11. "Approved" or "Approval" shall mean approval in writing.
- 3.1.12. "Month" shall mean English Calendar Month
- 3.1.13. "Day" shall mean English Calendar Day.
- 3.1.14. "Completion" means the fulfillment of the supply/work of Equipments/vessels and related services by the contractor in accordance with the terms and conditions set forth in the contract.
- 3.1.15. "Tender" means the offer of the contractor along with all other relevant documents as referred to in the contract.
- 3.1.16. "Engineer In-charge" shall mean Assistant Engineer (M), PMW, Cochin Port Trust.
- 3.2. The drawings given if any are only intended to cover the general layout and are not provided with dimensions / material of construction details. The tenderer shall collect all details from the Engineer-in-charge of the vessel/MES, CoPT for this work before preparing the price schedule.
- 3.3. **Tenderer shall be required to quote the rate of repair cost of all line item without GST. GST will be paid by CoPT additionally on production of relevant invoice. Statements such as "all taxes and duties applicable will be extra" should be avoided. Tenderer is required to quote the rate of repair cost of all line item including material costs.** The price shall be quoted by filling the prescribed format (**Schedule B1&B2**) of price schedule **on line only**. The Cochin Port Trust does not have any concessional forms, such as 'C' and 'D' forms. The rates quoted should be firm without any price variation clauses.

Cochin Port Trust
TENDER No.MD/PMW/ GHDNS GRAB REPAIRS /2020-22

- 3.4. Any penal interest, penalty or fine payable / paid by the contractor to the Tax Authorities on the Taxes and Duties shall not be paid / reimbursed by the employer under any circumstances.
- 3.5. Contractor to inform himself fully: The Contractor shall be deemed to have carefully examined the general conditions of contract, specifications, and form of tender and informed himself full regarding the conditions in which the contract is to be executed, the rules and regulations and all other matters and things affecting the cost of the work and satisfied himself fully regarding the sufficiency of his tender to cover all his obligations under the contract.
- 3.6. **Security Deposit:** The successful tenderer will be required to furnish Bank Guarantee towards Security Deposit for 10% of contract price on a stamp paper of value Rs 200/- within 15 days from the date of acceptance of work order by the contractor. The Bank Guarantee furnished towards the security deposit shall be valid up to 28 months from the date of receipt of work order. In case of extension of contract period, Bank Guarantee has to be extended for a further period as required by Cochin Port Trust. Any expenditure in this regard will be borne by the contractor. The proforma of Bank Guarantee for Security Deposit is appended along with this tender document as Form-I. Bank Guarantee has to be furnished in this format. If the contractor/supplier fails to perform or observe any of the conditions of contract, Port Trust will be at liberty to deduct any amount due to Port Trust under this contract from Security Deposit/any sums of money due or that may become due to the contractor/Supplier. This is without prejudice to the rights of the Port Trust under the terms of this Contract.
- 3.7. **Contract Agreement:** The successful Tenderer will be required to execute an agreement at his expense on Two Hundred Rupees (Rs.200/-) Kerala Stamp Paper in the proper departmental format (Form II) for the due and proper fulfillment of the contract, within 30 days from the date of acceptance of work order by the contractor. Pending preparation and execution of the contract agreement as above, the tender submitted by the tenderer together with Deputy Conservator's letter / fax accepting the tender shall constitute a binding contract between the Board and the contractor.
- 3.8. All safety protection / precaution as per Statutory and Regulatory requirements for the safety of the workmen, supervisors and materials are to be provided by the contractor.
- 3.9. When the work is over in CoPT premises if required, the Contractor should remove all his temporary plants, tools, etc. at his own expense and leave the whole area used by him in a clear and tidy condition to the satisfaction of the employer.
- 3.10. The contractor shall execute minor repair at CoPT premise if required, after getting sanction from the engineer in charge, works in such a manner that all the existing structures overhead lines, existing pipelines, utilities, etc. other than those covered under this contract are not disturbed /altered / damaged. Any damages caused shall be made good by the Contractor at his own risk and cost.
- 3.11. The Contractor will have to obey by the various Labour Laws and Regulations including P.F Act, Workmen compensation Act, Contract Labour (Regulation & Abolition) Act etc. or other Statutory Requirement if any, if applicable when working in Port premises.
- 3.12. The men deployed for the work and the materials brought by the Contractor to CoPT premises shall be insured at his own cost and the Port will no way be responsible for the loss / damages to the materials in connection with the work (assembling, commissioning, testing, guarantee repairs etc). The Contractor may insure all his employees against any accidents during the period of his contract and guarantee period.

Cochin Port Trust
TENDER No.MD/PMW/ GHDNS GRAB REPAIRS /2020-22

- 3.13. Alterations & Additions: Should any alterations or additions to the work as specified in the said scope of work not involving extra cost to the Contractor be considered necessary or expedient by either party and be mutually agreed or in writing, the Contractor shall execute the same without any charge beyond the contract price. But if the Port desires any alterations or additions involving extra cost to the Contractor, the Contractor before executing the same, arrive at a mutual agreement regarding the cost and time for such alterations and additions.
- 3.14. Rejections and Replacements: All materials, equipment and workmanship used and employed in carrying out this contract shall be to the entire satisfaction of the CoPT. Any portion or portions of materials, equipment or any of the works done under this contract which may be considered to be defective or unsatisfactory or not in accordance with the said specifications and plans and the requirements, which they shall reject and shall be replaced to the satisfaction of CoPT at the sole expense of the Contractor.
- 3.15. Indemnify against Accident and Damage: The Contractor shall be held liable and responsible for all accidents or damages to work during the contract work from whatsoever cause arising, and chargeable for anything that may be lost, stolen, damaged, removed or destroyed at any time till the system is accepted by the employer and shall also be held responsible and guarantee to make good any damage to or defects in the said work or any portion thereof due to materials, workmanship or design which appear after completion of each work or become known before the expiry of the guarantee period if any, notwithstanding that such damage/defect might not have been discovered during the tests or trials or that payment may wholly or partially have been made or that the work may have been approved earlier as properly completed and no certificate of approval of any work or materials by the employer shall affect or prejudice the right of the Board of Trustees against the Contractor or be considered conclusive as to the sufficiency of such work or materials. The Contractor shall solely be responsible for and shall make good and compensate any damage or injury, sustained by any person or property during the construction or working thereof up to the expiry of the guarantee period if any occasioned by reason if such defective construction or delivery or by reason of the failure of any portion thereof, or in consequence of any operations of the Contractor or his agents and he shall also be indemnify and keep indemnified and harmless the Board of Trustees and their representatives from and against all suits, actions, claims, penalties, liabilities, cost, expenses and demands whatsoever in connection with the work during the period of execution of contract and also against losses, damages, compensations, accidents, cost and expenses incurred.
- 3.16. Quality of materials and workmanship: All the equipments, components, accessories etc. used if any shall be brand new and readily available in open market. All items offered shall be as per approved quality and standards. They shall be of such design, size and material as to function satisfactorily under the rated conditions of operation and to withstand the environmental conditions at site. The type test certificates, routine test certificates and acceptance test certificates are also to be submitted. The Contractor shall execute in the best and most workmen like manner all works according to the true intent and meaning of the specifications of the contract and complete the same to the entire satisfaction of the CoPT.
- 3.17. Obligation to carry EIC's Instructions: The Contractor shall also satisfy the Port Trust that adequate provision has been made (i) to carry out his instructions fully and with promptitude; (ii) to ensure tha, parts required to be inspected before use are not used

Cochin Port Trust
TENDER No.MD/PMW/ GHDNS GRAB REPAIRS /2020-22

- before inspection and (iii) to prevent rejected parts being used in error. Where parts rejected by the Port Trust have been rectified or altered, such parts shall be segregated for separate inspection and approval before being used in the work.
- 3.18. Responsibility for completeness: Any minor work which may not be specifically mentioned in the specification/scope of work but which are usual or necessary are to be provided/done by the contractor without extra charge and the work must be complete in all details.
- 3.19. Workmen Compensation: The contractor shall indemnify the Employer in the event of the Trustees being held liable to pay compensations for the injury to any of the contractor's servants or workmen under the Indian Workmen's Compensation Act, 1923 as amended from time to time and shall take an Insurance Policy covering all risks under the Act and shall keep the same renewed from time to time as necessary for the duration of the contract and produce the same to the Employer On demand whenever so required.
- 3.20. Work on Sundays and holidays: No delivery of Grabs /work shall be carried out on Sundays and other holidays and beyond working hours on working days without the sanction in writing of the officer concerned. The contractor is liable to attend work at any time beyond the CoPT normal working hours, as and when required in emergency with the same rates and conditions. The normal working hours of the Port Trust are from 8:00 AM to 4:00 PM on all week days with half an hour interval between 12 noon to 12.30 PM.
- 3.21. Sum payable by way of compensation to be considered as reasonable compensation without reference to actual loss: All sums payable by way of compensation under any of these conditions shall be considered as reasonable compensation to be applied to the use of the Board without reference to the actual loss or damage sustained and whether or not any damage shall have been sustained.
- 3.22. Changes in constitution of firm: In the case of a tender by partners any change in the constitutions of the firm shall be forthwith notified by the Contractor to the Deputy Conservator for his information.
- 3.23. Governing Law: The contract shall be governed by and interpreted in accordance with the laws of India, unless otherwise specified in special conditions of contract. Any suit or other proceedings relating to this contract shall be filed, taken by the contractor in a Court of Law only in Cochin. Any work of an electrical nature to be executed under the contract shall comply with provisions of The Electricity Act 2003 (Central Act 36 of 2003) and the Rules there under for the time being in force.
- 3.24. Dock Safety: For the work carried out within dock area in the vicinity of any wharf or quay, the contractor shall abide by all the provisions of the Dock Workers (Safety, Health & Welfare) Regulation 1990.
- 3.25. Subcontracting: The contractor shall notify the Employer in writing of all subcontracts awarded under the contract if not already specified in the tender. Such notification, in the original Tender or later shall not relieve the Contractor from any of its obligations, duties, responsibilities, or liability under the contract.
- 3.26. Termination for Default: The Cochin Port Trust, without prejudice to any other remedy for the breach of Contract, by written notice of default sent to the Contractor, may terminate the contract in the whole or in part:
- 3.26.1. If the contractor fails to perform the work within the period specified in each work order or any other extension granted by CoPT
- 3.26.2. If the contractor fails to perform any other obligation under the contract.

Cochin Port Trust
TENDER No.MD/PMW/ GHDNS GRAB REPAIRS /2020-22

- 3.26.3. If the contractor, in the judgment of the Employer has engaged in fraud and corruption, in competing for or in executing the contract.
- 3.27. Cochin Port reserves the right to entrust another contractor for the same work during the contract period.
- 3.28. Termination for Insolvency: The Cochin Port Trust may at any time terminate the Contract by giving notice to the Contractor if the Contractor becomes bankrupt or otherwise insolvent. In such event, termination will be without compensation to the Contractor, provided that such termination will not prejudice or affect any right of action or remedy that has accrued or will accrue thereafter to Cochin Port Trust
- 3.29. Termination for Convenience: Cochin Port Trust, by notice sent to the Contractor, may terminate the Contract, in whole or in part, at any time for its convenience. The notice of termination shall specify that termination is for the Cochin Port Trust's convenience, the extent to which performance of the Contractor under the Contract is terminated, and the date upon which such termination becomes effective.
- 3.30. Cochin Port Trust's Lien: Cochin Port Trust shall have lien on all or any moneys that may become due and payable to the contractor under these presents or in respect of any debt or sums that may become due and payable by Cochin Port Trust to the contractor either alone or jointly with another or others and either under this or under any other contact or transaction of any nature whatsoever between the Cochin Port Trust and the Contactor.
- 3.31. All statutory approvals if any are in the contractor's scope.

SECTION IV. SPECIAL CONDITIONS and Scope of work

The Special Conditions will supersede the general conditions of contract wherever they differ.

- 4.1. This tender is for **Rate Contract for Repairs of Grabs of GHD Nehru Shatabdi for Two years**. Contract covers maintenance/repairs of grabs of Cochin Port Trust's Dredger, 'GHD Nehru Shatabdi'. Works detailed in the price schedule comprises of various works connected with repair / reconditioning of grabs. It is not necessary that all the works listed in the schedule of work are to be carried out on all grabs taken up for repairs. Drawings and parts of grab are detailed in *Annexure-1*. **The contractor can take the grab/ components to his work shop to carry out repair works.**
- 4.1. The Contract will be valid for a Period of **TWO years from date of work order**. No variation in the rates quoted will be permitted during the contract period. All repairs/renewal works of Grabs arising during the period should be attended by the Contractor. **Tenderers are required to quote the rate for all of the various items listed in the price schedule B1&B2. Incomplete price schedule will not be considered for evaluation.** Repair works on grabs during the contract period should be executed at the rates quoted in the price schedule B1&B2 by the contractor.
- 4.2. During the contract, the Employees deputed for work at CoPT premises, if any may be kept insured by the contractor at his own expenses against Personal Accident Risk.
- 4.3. The Contractor shall preferably be registered under EPF and ESI Act and the employees employed under them shall be covered in the EPF and ESI scheme.
- 4.4. **All labour, materials and consumables required for repairs of the grab shall be in the scope of the contractor and cost of same also should be included in the quoted rate. Equipments like crane and Fork lift for loading and unloading the**

Cochin Port Trust
TENDER No.MD/PMW/ GHDNS GRAB REPAIRS /2020-22

- grabs to and from the contractor's vehicle will be arranged by CoPT **only in Port premises.**
- 4.5. The contractor should employ sufficient number of working groups consisting of skilled workers and supervisors simultaneously to carry out the work. Supervisors must be qualified, experienced and must have capability and responsibility to interact with Port Officers.
 - 4.6. Based on the schedule of work and rate as per Schedule B1&B2, separate work orders will be issued for each Grabs renewal/repair works.
 - 4.7. As and when repair/renewal work arises, verbal, SMS or e-mail intimation will be given to the contractor. The work should be commenced immediately on receipt of such intimation of CoPT. Firm work order will be issued subsequently. As and when defects are observed on any of the grabs, they will be placed at a quay (berth) where the dredger GHD Nehru Shatabdi can be berthed and will be intimated to the contractor via phone/sms/e-mail.
 - 4.8. **The contractor can take the grab/ components to his work shop to carry out repair works.** In such situation, the contractor will be responsible for the safe custody of grab taken to their workshop and responsible for the loss / damages caused to the grab. The contractor is liable for the payment towards damage/loss, as per the cost assessed by CoPT. The contractor shall compensate for the loss / damages, if any, caused to the grab during this period.
 - 4.9. **The repair/renewal works of each grabs shall be done at contractor's site. After receiving work order for each grab, the contractor shall transport the grab to his site for repairs and bring back to CoPT premises after repairs by contractors vehicle and his own risk and unload it to the berths as per EIC's instruction.**
 - 4.10. After dismantling the defective grab by the contractor at his site, **Engineer-in-charge will survey and list out details of work. Based on this, individual work order will be placed for each grab, line item wise as per the price schedule.**
 - 4.11. The contractor has to carry out all necessary repairs, including handling and transporting of grabs or its components from the CoPT berths to the contractors workshop and back, at his own and risk. CoPT will provide **cranes/lifting equipments free of cost** for loading/unloading the grab/ its components into/from the contractors' vehicle at CoPT premises. Any minor work which is required to be carried out during commissioning/operation of grabs will be permitted to undertake in CoPT premises.
 - 4.12. After repairs, all lubricating points of grab assembly shall be lubricated by the contractor.
 - 4.13. Work completion period for each grab will be **15 days (maximum)** from the date of handing over of grab to the contractor. However, the contractor shall make all efforts to complete the work in minimum time. On justifiable circumstance, additional time for completion of the work will be granted by EIC up on request of the contractor.
 - 4.14. **The contractor should give a Guarantee of Three months for each repaired grab from the date of fitting the grab in the vessel for operation after repairs, for workmanship /materials used for repairs.**
 - 4.15. **90% payment for each grab will be made on satisfactory completion of work,** which means completion of entire work mentioned in the corresponding work order and bringing back the grabs to CoPT premises and unloading the same to the berth as per the Engineer in charge's instruction and submission of relevant GST invoice. The invoices for each grabs shall be addressed to SE (M) T T, Cochin Port Trust. Balance

Cochin Port Trust
TENDER No.MD/PMW/ GHDNS GRAB REPAIRS /2020-22

- 10% will be paid after the guarantee period of **3months** from date of fitting the grab in the vessel for operation, as certified by MES.
- 4.16. Any defect / damage found in the attended work during initial operation of grab after repairs, due to poor workmanship / material used by the contractor, should be rectified by the contractor at his sole risk and cost and to the entire satisfaction of the Engineer-in-Charge within the guarantee period of three months
 - 4.17. Income tax at the prevailing rate will be deducted from each bill.
 - 4.18. The contractor will be responsible for the safe custody of Grabs taken for repairs from Port Trust and till return after repairs to CoPT premises. Any expenditure due to loss or damage to such materials and also to any property of the owner caused on account of this work will be realised from the contractor.
 - 4.19. Cochin Port reserve the right to cancel this contract at any time during the tenure of the contract without assigning any reason thereof. Cochin Port also reserves the right to entrust another contractor for the same work during the contract period.
 - 4.20. The Contractor himself has to ascertain the labour situation and trade union problems prevailing at the site and is liable to sort out any problems in connection with the contract at his own risk so as not to affect the work. Without consent or knowledge of the Employer, contractor should not make any agreement or settlement with Unions.

.....

Annexure I. Drawings and Part numbers
DRG. NO. 1 : SUSPENSION

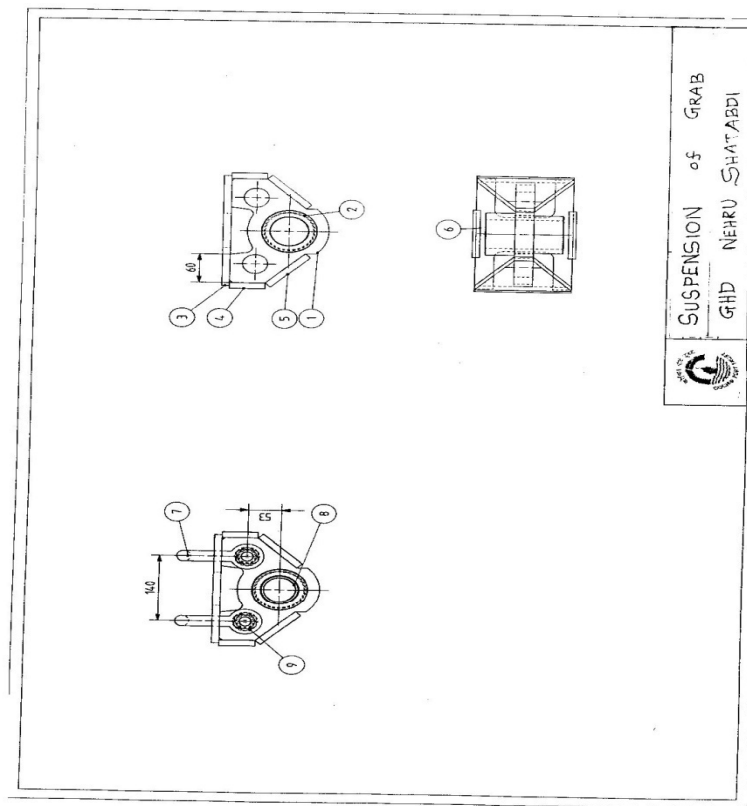

Part. No.	Description of Item	Quantity in Nos.
1.1	Main Plate	1
1.2	Outside Bush	1
1.3	Upper Plate	1
1.4	Plate	2
1.5	Protection Plate	2
1.6	Protection Plate	2
1.7	D Shackle	4
1.8	Clamping Bush	1
1.9	Bearing Bush; D Shackle	2

DRG. NO. 2 : SUSPENSION SET

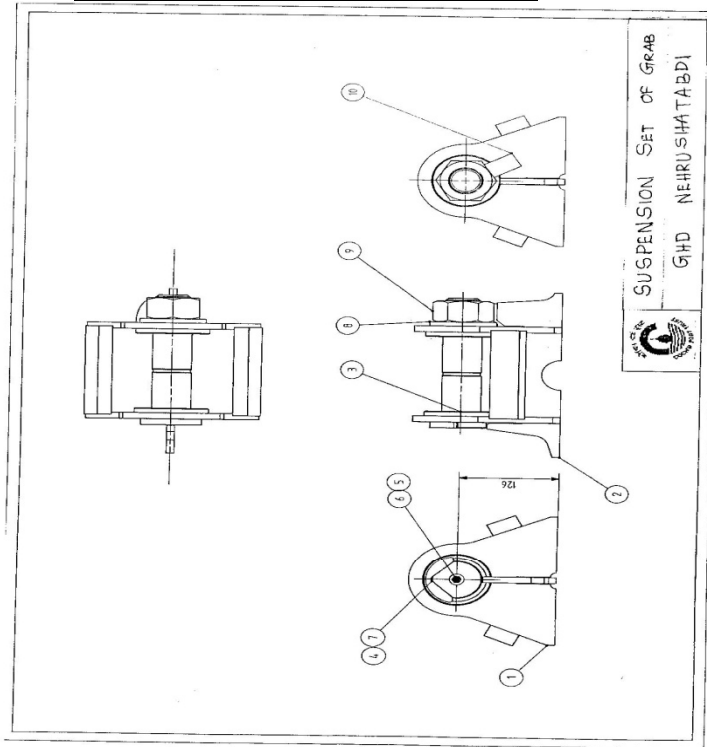

Part. No.	Description of Item	Quantity in Nos.
2.1	Plate; Suspension	2
2.2	Protection Plate	1
2.3	Ring	2
2.4	Pin; Suspension	1
2.5	Lubricating Nipple	1
2.6	Expansion Plug	1
2.7	Locking Plate	1
2.8	Steel Washer	1
2.9	Nut	1
2.10	Locking Plate	1
2.11	Strip	2

DRG. NO. 3 : ROPE GUIDING POT

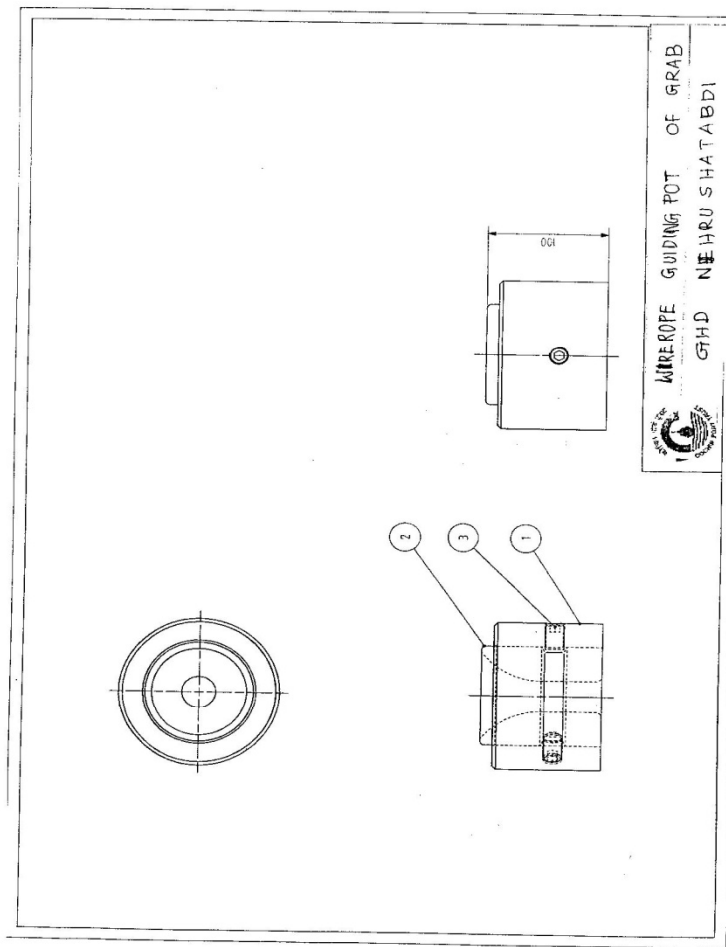

Part. No.	Description of Item	Quantity in Nos.
3.1	Outside Bush	1
3.2	Rope Guide Pot	1
3.3	Adjusting Screw with Hexagon Socket	2

DRG. NO. 4 : HEAD

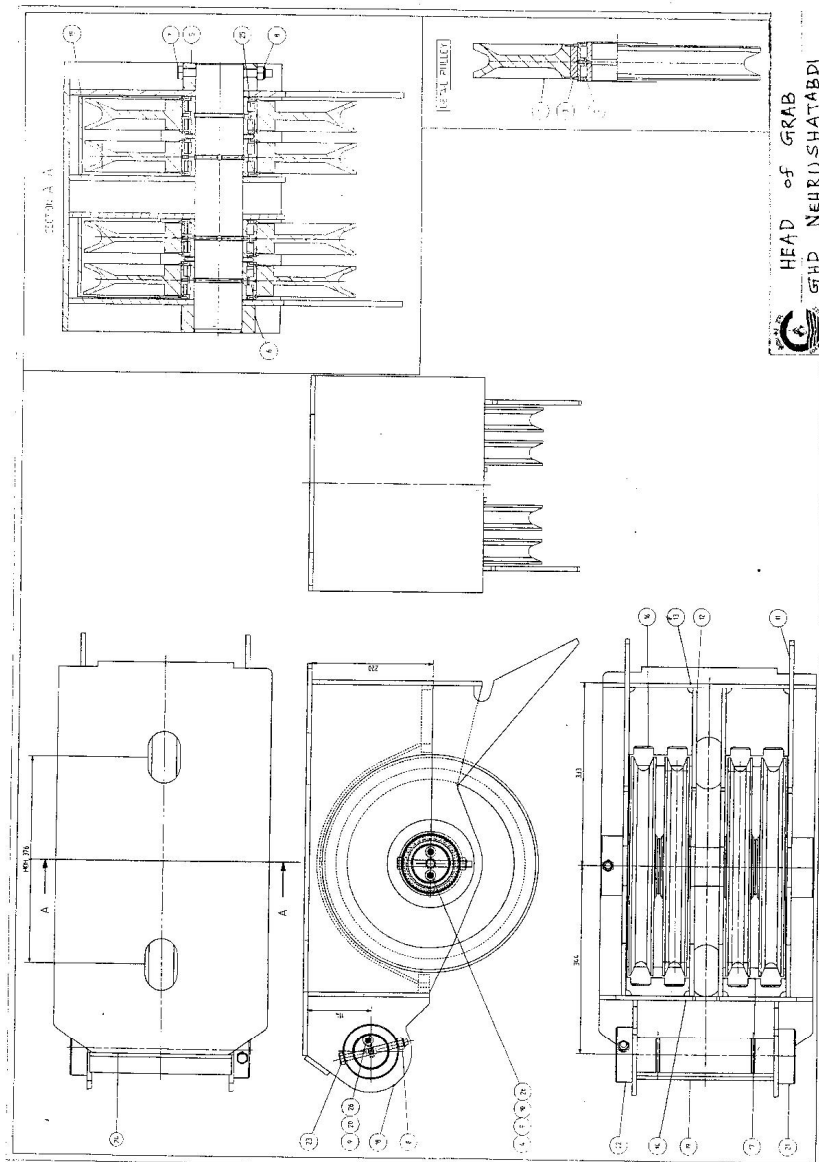

Cochin Port Trust
TENDER No.MD/PMW/ GHDNS GRAB REPAIRS /2020-22

Part. No.	Description of Item	Quantity in Nos.
4.1	Wire Rope Pulley	4
4.2	Cylinder Roller Bearing	4
4.3	Locking Ring	8
4.4	Shaft; Pulley	1
4.5	Ring	1
4.6	Ring	1
4.7	Bolt	1
4.8	Nut; Nyloc	2
4.9	Lubricating Nipple	6
4.10	Expansion Plug	1
4.11	Pulley Plate; Outside	2
4.12	Pulley Plate; Between	2
4.13	Back Plate	1
4.14	Intermediate Plate	1
4.15	Plate	2
4.16	Cam Plate; Large	2
4.17	Cam Plate; Small	2
4.18	Ear Plate	2
4.19	Strip	1
4.20	Shaft; Arm	1
4.21	Ring	1
4.22	Ring	1
4.23	Bolt	1
4.24	Upper Plate	1
4.25	Ring	2
4.26	Expansion Plug	6

DRG. NO. 5 : UNDER BLOCK

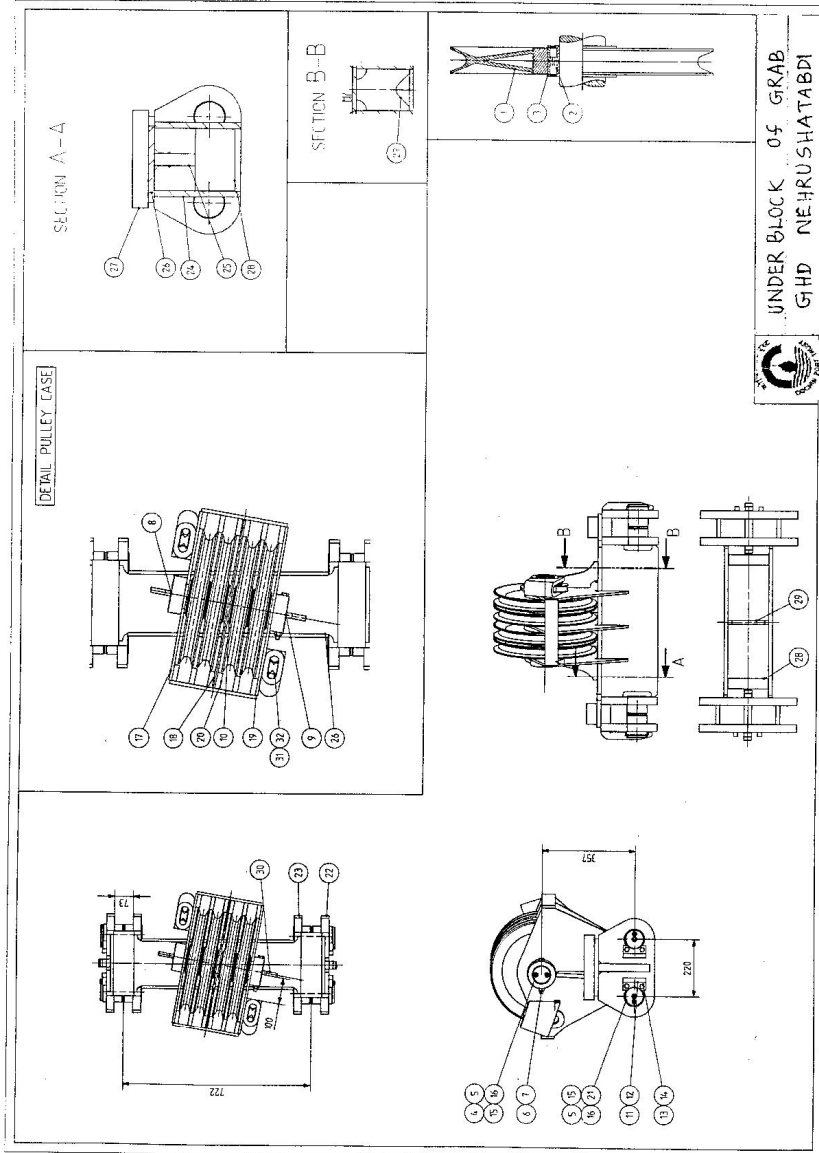

Cochin Port Trust
TENDER No.MD/PMW/ GHDNS GRAB REPAIRS /2020-22

Part. No.	Description of Item	Quantity in Nos.
5.1	Wire Rope Pulley	4
5.2	Cylinder Roller Bearing	4
5.3	Locking Ring	8
5.4	Shaft; Pulley	1
5.5	Expansion Plug	5
5.6	Bolt	1
5.7	Nut; Nyloc	1
5.8	Ring	1
5.9	Ring	1
5.10	Ring	1
5.11	Key; Shaft	4
5.12	Square	4
5.13	Bolt	8
5.14	Spring Washer	8
5.15	Lubricating Nipple	8
5.16	Expansion Plug	8
5.17	Pulley Plate; Outside	2
5.18	Pulley Plate; Between	1
5.19	Strip	2
5.20	Strip	12
5.21	Shaft; Turning Point	4
5.22	Ear Plate; Under Block	2
5.23	Ear Plate; Under Block	2
5.24	Shore Plate	2
5.25	Intermediate Plate	2
5.26	Upper Plate	1
5.27	Plate	2
5.28	Plate	2
5.29	Strengthening Plate	1
5.30	Strengthening Plate	2
5.31	Socket; Cut Off	2
5.32	Wedge	2

DRG. NO. 6 : SCOOP

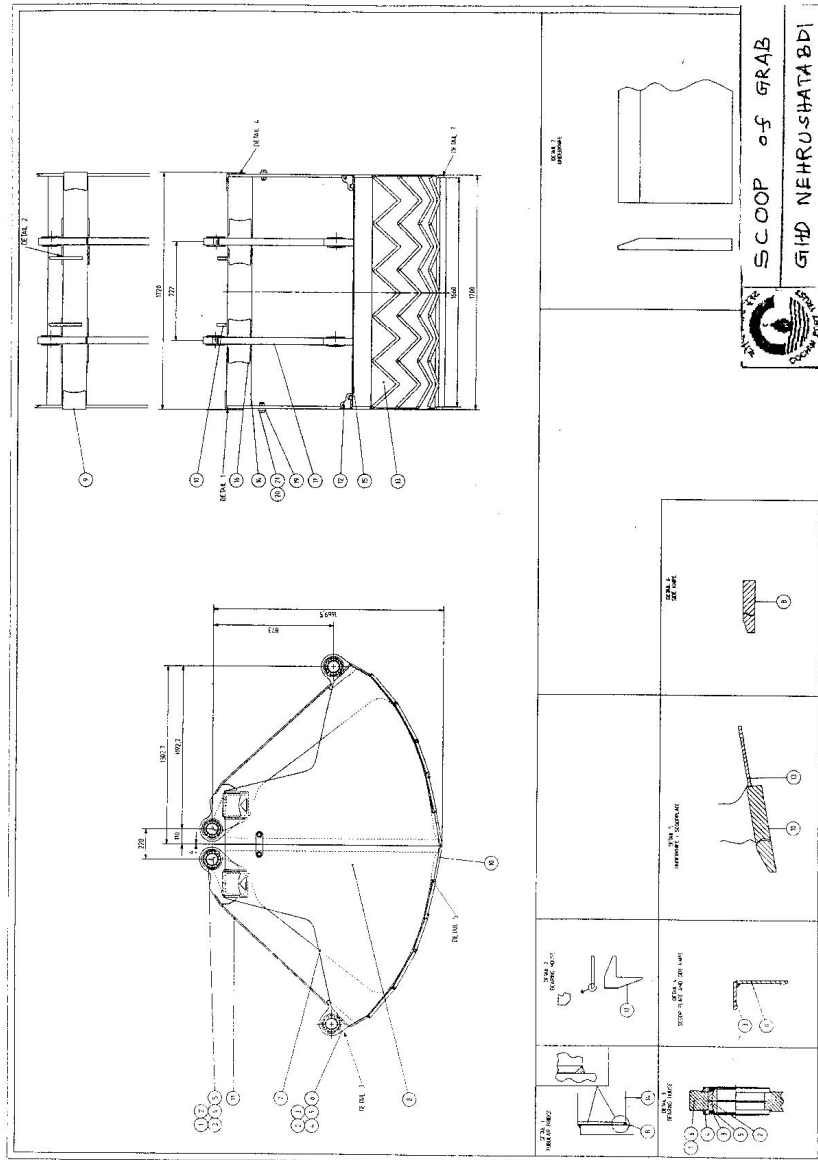

SC. COOP of GRAB
 GHD NEHRUSHATABDI

Cochin Port Trust
TENDER No.MD/PMW/ GHDNS GRAB REPAIRS /2020-22

Part. No.	Description of Item	Quantity in Nos.
6.1	Bearing House	8
6.2	Spherical Bearing	8
6.3	CD Sealing Ring	16
6.4	Locking ring	16
6.5	Ring	16
6.6	Bearing House; Arm	4
6.7	Shore Plate	4
6.8	Side Knife	4
6.9	Strengthening Plate	4
6.10	Under Knife	2
6.11	Strip	4
6.12	Strengthening Plate	4
6.13	Scoop Plate	2
6.14	Tubular Bridge	2
6.15	Strip; Back Strip	2
6.16	Base Plate	8
6.17	Stop Plate	4
6.18	Round	80
6.19	Transport Plate	2
6.20	Bolt	4
6.21	Nut	4

DRG. NO. 7 : ARM

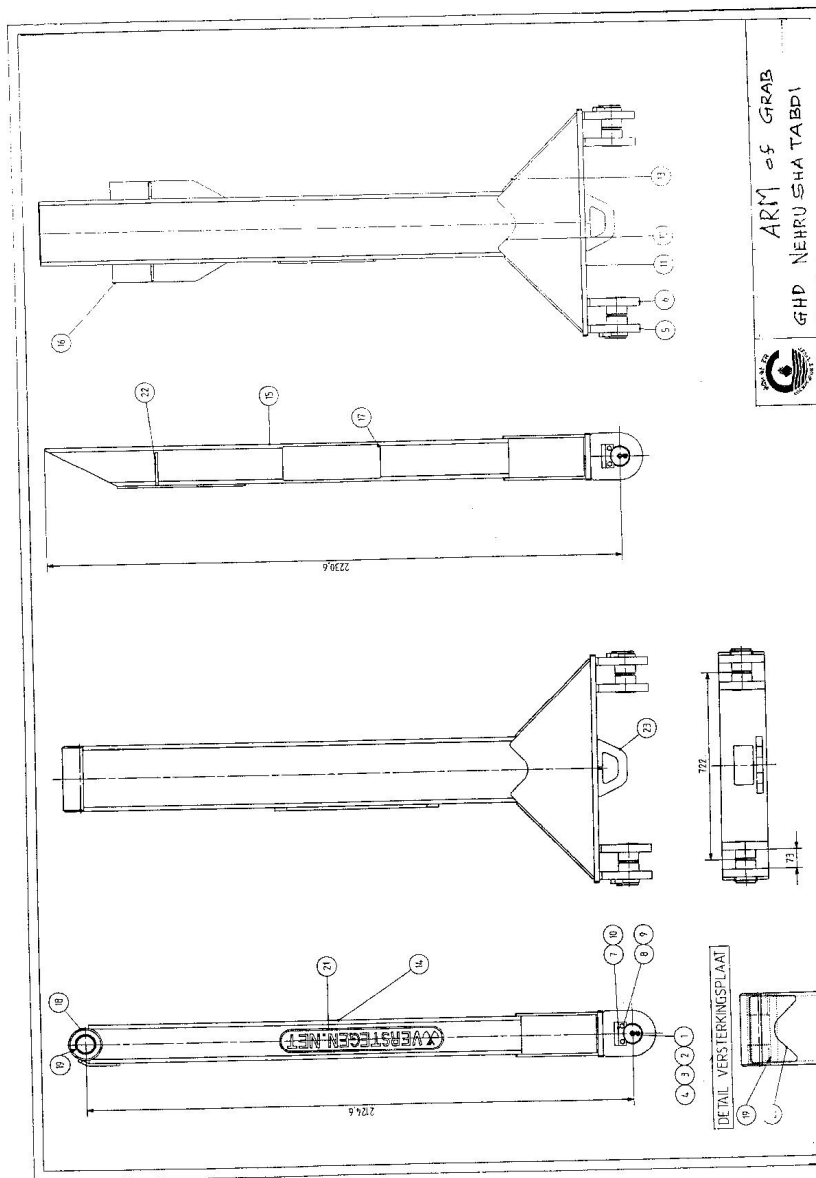

Cochin Port Trust
TENDER No.MD/PMW/ GHDNS GRAB REPAIRS /2020-22

Part. No.	Description of Item	Quantity in Nos.
7.1	Shaft; Turning Point	4
7.2	Lubricating Nipple	4
7.3	Expansion Plug	4
7.4	Expansion Plug	4
7.5	Ear Plate; Outside / Arm / Inside	12
7.6	Ear Plate; Outside / Arm / Inside	12
7.7	Key; Shaft	4
7.8	Bolt	8
7.9	Spring Washer	8
7.10	Square	4
7.11	Base Plate	2
7.12	Strengthening Plate	4
7.13	Strip	4
7.14	Box Profile; Arm Mobile	1
7.15	Box Profile; Arm Fixed	1
7.16	Head Connecting Plate	1
7.17	Number Plate	1
7.18	Outside Bush	1
7.19	Bearing Bush	2
7.20	Strengthening Plate	1
7.21	Name Plate	1
7.22	Strengthening Plate	2
7.23	Bobcat Plate	2

SCHEDULE - A.

**LIST OF SCANNED DOCUMENTS TO BE SUBMITTED
ONLINE IN THE TECHNOCOMMERCIAL BID**

Sl. No	Description of Documents	For documents submitted, mark "Yes"
1	Cost of Tender Documents in the form of DD.(Copy)	
2	EMD in the form of DD.(Copy)	
3	Tender document duly filled including blank price schedule B1&B2 , signed and stamped on all the pages.	
4	Copies of work order/Purchase Order and completion certificate to prove MQC	
5	Scanned Copies of profit and loss statement, balance sheets and auditor's report / annual report for the last 3 years ending 31.03.2019	
6	Scanned Copy Details of financial stability (Schedule C).	
7	Scanned Copy Structure of organization (Schedule D).	
8	Scanned Copy Details of experience (Schedule E).	
9	Scanned Copy Power of Attorney in favour of person authorized to sign the tender document.	
10	Scanned Copy of GST, PAN etc.	
11	Scanned Copy of Annexure I,II, III and Schedule A duly filled	

Note: Tenderer is required to mention relevant page numbers / marking of his offer while filling up the above format.

Signature of Tenderer with date and seal

Cochin Port Trust
TENDER No.MD/PMW/ GHDNS GRAB REPAIRS /2020-22

Price Bid

Price Schedule B1

Sl. No.	Part No.	Details of Work	Unit	Rate in Rs. per unit	Anticipate d qty. for 2 years	Amount in Rs.(Unit rate X Quantity)
1	1.2	Renewal of Outside Bush out of MS	Nos	1		
2	1.7	Renewal of 6.5 ton D Shackle	Nos	1		
3	1.8	Renewal of Clamping Bush out of EN 8 Steel 60x50x125	Nos	12		
4	1.9	Renewal of Bearing Bush of D Shackle out of EN 8 Steel	Nos	5		
5	2.3	Renewal of Ring out of EN 8 Steel	Nos	2		
6	2.4	Renewal of Pin of Suspension out of EN 8 Steel	Nos	11		
7	2.5	Renewal of Lubricating Nipple 1/8"	Nos	240		
8	2.6	Renewal of Expansion Plug 1/8"	Nos	1		
9	2.8	Renewal of MS Washer M45	Nos	1		
10	2.9	Renewal of MS Nut M45	Nos	1		
11	3.2	Repairs of Rope Guide Pot	Nos	1		
12	3.3	Renewal of Adjusting Screw with Hexagon Socket M16x25	Nos	1		
13	4.1	Renewal of Wire Rope pulley	Nos	11		
14	4.2	Renewal of Cylinder Roller Bearing with Nylon Bush	Nos	80		
15	4.4.1	Repairs of Pulley Shaft out of EN 8 Steel	Nos	1		
16	4.4.2	Renewal of Pulley Shaft out of EN 8 Steel	Nos	20		
17	4.5	Renewal of Ring out of MS	Nos	16		
18	4.6	Renewal of Ring out of MS	Nos	1		
19	4.7	Renewal of MS Bolt M12x130	Nos	60		
20	4.8	Renewal of Nyloc Nut M12	Nos	60		
21	4.9	Renewal of Lubricating Nipple 1/8"	Nos	1		
22	4.1	Renewal of Expansion Plug	Nos	1		
23	4.20.1	Repairs of Arm Shaft out of EN 8 Steel	Nos	1		
24	4.20.2	Renewal of Arm Shaft out of EN 8 Steel	Nos	20		
25	4.21	Renewal of Ring out of MS	Nos	1		
26	4.22	Renewal of Ring out of MS	Nos	4		
27	4.23	Renewal of MS Bolt M12x120	Nos	20		
28	4.25	Renewal of Ring out of Nylon	Nos	240		
29	4.26	Renewal of Expansion Plug 1/8"	Nos	1		
30	5.2	Renewal of Cylinder Roller Bearing with Nylon Bush	Nos	80		

Cochin Port Trust
TENDER No.MD/PMW/ GHDNS GRAB REPAIRS /2020-22

31	5.4.1	Repairs of Pulley Shaft out of EN 8 Steel	Nos	1		
32	5.4.2	Renewal of Pulley Shaft out of EN 8 Steel	Nos	20		
33	5.5	Renewal of Expansion Plug	Nos	1		
34	5.6	Renewal of MS Bolt M12x130	Nos	1		
35	5.7	Renewal of Nyloc Nut M12	Nos	1		
36	5.8	Renewal of MS Ring	Nos	2		
37	5.9	Renewal of MS Ring	Nos	1		
38	5.1	Renewal of MS Ring	Nos	1		
39	5.11	Renewal of MS Key of Shaft 30x15x90	Nos	1		
40	5.12	Renewal of MS Square	Nos	80		
41	5.13	Renewal of MS Bolt M10x30	Nos	1		
42	5.14	Renewal of Spring Washer M10	Nos	1		
43	5.15	Renewal of Lubricating Nipple 1/8"	Nos	1		
44	5.16	Renewal of Expansion Plug 1/8"	Nos	1		
45	5.21.1	Repairs of Turning Point Shaft out of EN 8 Steel	Nos	4		
46	5.21.2	Renewal of Turning Point Shaft out of EN 8 Steel	Nos	76		
47	6.1	Repairs of Bearing House by boring and bushing EN 8 Bush	Nos	1		
48	6.2	Renewal of Spherical Bearing with EN 8 steel bush	Nos	160		
49	6.6	Repairs of Bearing House of Arm by boring and bushing EN 8 Bush	Nos	160		
50	7.1.1	Repairs of Turning Point Shaft	Nos			
51	7.1.2	Renewal of Turning Point Shaft	Nos	80		
52	7.2	Renewal of Lubricating Nipple 1/8"	Nos	1		
53	7.3	Renewal of Expansion Plug 1/8"	Nos	1		
54	7.4	Renewal of Expansion Plug	Nos	1		
55	7.7	Renewal of MS Key of Shaft 30x15x90	Nos	1		
56	7.8	Renewal of MS Bolt M10x30	Nos	1		
57	7.9	Renewal of Spring Washer M10	Nos	1		
58	7.18	Renewal of Outside Bush out of MS	Nos	1		
59	7.19	Renewal of Bearing Bush out of Bronze	Nos	38		
60		Charges for to and fro transporting / handling of grab	Nos	20		
61		Charges for general cleaning and arranging for inspection of grab	Nos	20		
Total amount in figures :- Rs						
.....						
Total amount in words: - Rupees						
.....						

Cochin Port Trust
TENDER No.MD/PMW/ GHDNS GRAB REPAIRS /2020-22

Signature of the tenderer with date and seal

Price schedule B2

Sl. No.	Part No.	Details of Work	Unit	Anticipate d qty. for 2 years	Rate/ Kg in Rs.	Total Amount in Rs. (Unit rate X Quantity)
1	1.1	Repairs of Main Plate out of MS	Kg	Total quantity for items(1 to 63) will be 1001Kg		
2	1.3	Repairs of Upper Plate out of MS				
3	1.4	Repairs of Plate out of MS				
4	1.5	Repairs of Protection Plate out of MS				
5	1.6	Repairs of Protection Plate out of MS				
6	2.1	Repairs of Suspension Plate out of MS				
7	2.2	Repairs of Protection Plate out of MS				
8	2.7	Repairs of Locking Plate out of MS				
9	2.10	Repairs of Locking Plate out of MS				
10	2.11	Repairs of Strip out of MS				
11	4.11	Repairs of Outside Pulley Plate out of MS				
12	4.12	Repairs of Between Pulley Plate out of MS				
13	4.13	Repairs of Back Plate out of MS				
14	4.14	Repairs of Intermediate Plate out of MS				
15	4.15	Repairs of Plate out of MS				
16	4.16	Repairs of Large Cam Plate out of MS				
17	4.17	Repairs of Small Cam Plate out of MS				
18	4.18	Repairs of Ear Plate out of MS				
19	4.19	Repairs of Strip out of MS				
20	4.24	Repairs of Upper Plate out of MS				
21	4.27	Repairs of Wire Rope Guard out of 20 mm dia. MS Rod				
22	5.17	Repairs of Outside Pulley Plate				
23	5.18	Repairs of Between Pulley Plate				
24	5.19	Renewal of MS Strip				
25	5.20	Renewal of MS Strip				
26	5.22	Repairs of Under Block Ear Plate out of MS				
27	5.23	Repairs of Under Block Ear Plate out of MS				
28	5.24	Repairs of Shore Plate out of MS				
29	5.25	Repairs of Intermediate Plate out of MS				

Cochin Port Trust
TENDER No.MD/PMW/ GHDNS GRAB REPAIRS /2020-22

30	5.26	Repairs of Upper Plate out of MS				
31	5.27	Repairs for Plate out of MS				
32	5.28	Repairs for Plate out of MS				
33	5.29	Repairs for Strengthening Plate out of MS				
34	5.30	Repairs for Strengthening Plate out of MS				
35	5.31	Repairs of Cut off Socket out of MS				
36	5.32	Repairs of MS Wedge				
37	5.33	Repairs of Wire Rope Guard out of 20 mm dia. MS Rod				
38	6.7	Repairs of Shore Plate out of MS				
39	6.8	Repairs of Side Knife out of MS				
40	6.9	Repairs of Strengthening Plate out of MS				
41	6.10	Repair of Under Knife out of MS				
42	6.11	Repairs of Strip out of MS				
43	6.12	Repairs of Strengthening Plate out of MS				
44	6.13	Repairs of Scoop Plate out of MS				
45	6.14	Repairs of Tubular Bridge out of MS				
46	6.15	Repairs of Back Strip out of MS				
47	6.16	Repairs of Base Plate out of MS				
48	6.17	Repairs of Stop Plate out of MS				
49	6.18	Renewal of MS Round out of 20mm MS rod				
50	7.5	Repairs of Ear Plate out of MS				
51	7.6	Repairs of Ear Plate out of MS				
52	7.10	Repairs of MS Square				
53	7.11	Repairs of MS Base Plate				
54	7.12	Repairs of Strengthening Plate out of MS				
55	7.13	Repairs of MS Strip				
56	7.14	Repairs of Box Profile of Mobile Arm out of MS				
57	7.15	Repairs of Box Profile of Fixed Arm out of MS				
58	7.16	Repairs of Head Connecting Plate out of MS				
59	7.17	Repairs of Number Plate out of MS				
60	7.20	Repairs of Strengthening Plate out of MS				
61	7.21	Repairs of Name Plate out of MS				
62	7.22	Repairs of Strengthening Plate out of MS				
63	7.23	Repairs of Bobcat Plate out of MS				
Total amount in figures :- Rs						
Total amount in words: - Rupees						

Total Quoted price (B1+B2)

Grand Total amount (Sum of total amount in price schedule B1&B2) in figures:.....

Grand Total amount (Sum of total amount in price schedule B1&B2) in words:.....

Cochin Port Trust
TENDER No.MD/PMW/ GHDNS GRAB REPAIRS /2020-22

Note:

1. The quoted rate shall be excluding GST. GST will be paid additionally by CoPT on production of relevant invoice
2. The Estimated quantity mentioned above shall be taken for tender evaluation only. Actual quantity may be different from the above quantity.
3. **Tenderers are required to quote the rate for all of the various items listed in the price schedule B1&B2. Incomplete price schedule will not be considered for evaluation.**

Signature of the tenderer with date and seal

SCHEDULE. C-: DETAILS OF FINANCIAL STABILITY

35

FINANCIAL TURNOVER OF THE TENDERER DURING THE LAST THREE YEARS
ENDING 31-03-2019.

Sl. No.	Year	Turn Over
1.	2016-2017	
2.	2017-2018	
3.	2018-2019	

Signature of Tenderer with date and seal

SCHEDULE. D-: STRUCTURE OF ORGANISATION

NAME OF TENDERER:
POSTAL ADDRESS :

TELEPHONE :
TELEX/FAX :
E-Mail :
CONTACT PERSON :
TELEPHONE :
MOBILE :
TELEX/FAX :
E-Mail :

NATURE OF ORGANISATION: Proprietary/ Partnership/ Private Ltd Co. /Public Ltd. Co.

NAMES OF DIRECTORS :

REGISTRATION NO: OF FIRM/ COMPANY :
DATE OF REGISTRATION :

AUTHORITY OF AUTHORISED SIGNATORY:

Signature of Tenderer with date and seal

Upload scanned copies of registration of Firm/Company, details of
Proprietor/Partners/Directors
and Partnership Deed/Memorandum and Articles of Association in the e-tender.

Cochin Port Trust
TENDER No.MD/PMW/ GHDNS GRAB REPAIRS /2020-22

37

SCHEDULE. E:- DETAILS OF EXPERIENCE

DETAILS OF SIMILAR WOKRS/SUPPLIES MADE DURING THE LAST SEVEN (7) YEARS ending 31.05.2020						
Sl. No:	Particulars of supply/work done by the Tenderer	Value of contract	Delivery time as per contract (days)	Actual Delivery time(days)	Year of completion	Name & postal address of client with Telephone No:/e-mail

Signature of Tenderer with date and seal

Upload the scanned copies of Purchase orders / satisfactory performance report from the clients in the e-tender.

ANNEXURE. I

UNDERTAKING THAT NO CHANGES HAVE BEEN MADE IN THE TENDER
DOCUMENT DOWNLOADED

To

The Deputy Conservator,
Cochin Port Trust,
Cochin 682009.
Kerala, India.

Dear Sir,

We.....
.....
.....do hereby confirm that no changes have been made in the tender
document downloaded and submitted by us for the Tender No. MD/PMW/ GHDNS
GRAB REPAIRS /2020-22

Yours faithfully,

Signature of the Tenderer.

Name & Designation

Annexure II.

39

**PROFORMA OF UNDERTAKING REGARDING ILLEGAL METHODS FOR
INFLUENCING TENDER PROCESS**

To
The Deputy Conservator,
Cochin Port Trust,
Cochin 682009.
Kerala, India.

Dear Sir,

I/ We do hereby undertake that I/We have not made any payment or illegal gratification to any person/authority connected with the Tender process of Tender No.MD/PMW/ GHDNS GRAB REPAIRS /2020-22 so as to influence the Tender process and have not committed any offence under the PC Act in connection with the Tender.

Yours faithfully,

Signature of tenderer :

Name & Designation :

Cochin Port Trust
TENDER No.MD/PMW/ GHDNS GRAB REPAIRS /2020-22

Annexure III.

40

**PROFORMA OF DISCLOSURE OF PAYMENT MADE/ PROPOSED TO BE MADE
TO THE INTERMEDIARIES IN CONNECTION WITH THE TENDER**

To
The Deputy Conservator,
Cochin Port Trust,
Cochin 682009.
Kerala, India.

Dear Sir,

I/We have made / proposed to make the following payments in connection with the

TENDER No.MD/PMW/ GHDNS GRAB REPAIRS /2020-22.

1. _____ to Mr./Ms./Messrs _____
_____ (Name and Address)
2. _____ to Mr./Ms./Messrs _____
_____ (Name and Address)
3. _____ to Mr./Ms./Messrs _____
_____ (Name and Address)

Yours faithfully,

Signature of tenderer :

Name & Designation :

Note: **In case no payment is made or proposed to be made a 'Nil' statement shall be enclosed.**

Cochin Port Trust
TENDER No.MD/PMW/ GHDNS GRAB REPAIRS /2020-22

Form I. Form of Bank Guarantee

41

FOR SECURITY DEPOSIT
(TO BE EXECUTED ON STAMP PAPER WORTH RS.200/-)
GUARANTEE BOND NO.

In consideration of the Board of Trustees of the Port of Cochin (hereinafter called the "Port Trust" which expression shall include their successors and assignees) having accepted the tender No..... datedsubmitted by M/s..... (Name & address of tenderer).... (hereinafter called "the said tenderer") for (name of work)..... as per the Deputy Conservator Cochin Port Trust's order No dated and having agreed to exempt M/s (Name & address of tenderer)..... (hereinafter called as the "tenderer)" which expression shall include their successors and assignees) from the demand under the terms and conditions of the said tender and the agreement to be executed between the Port Trust and the said tenderer and which shall include any amendments, alterations or additions made with the mutual consent between the parties (hereinafter called " the said agreement") of Security Deposit for the due fulfillment by the said tenderer(s) of the terms and conditions contained in the said tender and Agreement, on production of a Bank Guarantee for Rs.(Rupees only).

We,..... (Name of Bank) (hereinafter referred to as "the Bank") do hereby undertake to pay to the Port Trust an amount not exceeding.....(Rupees...only) against any loss or damage caused to or suffered by the or would be caused to or suffered by the port Trust by reason of any breach by the said Tenderer(s) of any of the terms or conditions contained in the agreement.

We, Bank Ltd., do hereby undertake to pay the amounts due and payable under this guarantee without any demur, merely on a demand from the Port Trust stating that the amount claimed is required to meet the recoveries due or likely to be due from the said tenderer(s). Any such demand made on the Bank shall be conclusive as regards the amount due and payable by the Bank under this guarantee. However, our liability under this guarantee shall be restricted to an amount not exceeding Rs.

We,..... Bank Ltd., undertake to pay to the Port Trust any money so demanded notwithstanding any dispute or disputes raised by the tenderer(s) in any suit or proceeding pending before any court or Tribunal relating thereto, our liability under this present being absolute and unequivocal. The payment so made by us under this bond shall be a valid discharge of our liability for payment there under and the tenderer(s) shall have no claim against us for making such payment.

We Bank ltd., further agree that the guarantee herein contained shall remain in full force and effect during the period that would be taken for the performance of the said agreement and that it shall continue to be enforceable till all the dues of the Port Trust under or by virtue of the said agreement have been fully paid and its claims satisfied or discharged or till Engineer – in – charge on behalf of the Port Trust

Cochin Port Trust
TENDER No.MD/PMW/ GHDNS GRAB REPAIRS /2020-22

42

certifies that the terms and conditions of the said agreement have been fully and properly carried out by the said tenderer(s) and accordingly discharges this guarantee.

We,..... Bank Ltd., further agree with the Port Trust that the Port Trust shall have the fullest liberty without our consent and without affecting in any manner our obligations hereunder to vary any of the terms and conditions of the said Agreement or to extend time of performance by the said tenderer(s) from time to time or to postpone for any time or from time to time any of the powers exercisable by the Port Trust against the said tenderer(s) and to forbear or enforce any of the terms and conditions relating to the said Agreement and we shall not be relieved from our liability by reason of any such variation, or extension being granted to the said tenderer (s) or for any forbearance act or omission on the part of the Port Trust or any indulgence by the Port Trust to the said tenderer(s) or by any such matter or thing whatsoever which under the law relating to sureties would but for this provision, have effect of so relieving us.

This guarantee will not be discharged due to the change in the constitution of the Bank or the tenderer(s).

We, Bank Ltd., lastly undertake not to revoke this guarantee except with the previous consent of the Port trust in writing. This guarantee shall be valid up to unless extended on demand by Port Trust. Notwithstanding anything mentioned above, our liability against this guarantee is restricted to Rs. (Rupees..... only) and unless in claim in writing is lodged with us within six months of the date of expiry or the extended date of expiry of this guarantee, all our liabilities under this guarantee shall stand discharged.

SIGNATURE

Dated theday of.....
for Bank Ltd.

Cochin Port Trust
TENDER No.MD/PMW/ GHDNS GRAB REPAIRS /2020-22

Form II. Proforma of Agreement

43

TO BE EXECUTED ON KERALA STAMP PAPER (Rs.200/-)

AGREEMENT NO. OF.....

This agreement is made at Cochin this the-----day of -----, Two Thousand-----and-----between-----represented by Sri. -----aged -----years, son of Sri. -----residing at ----- (House name and No.) ----- District ----- State ----- (hereinafter referred to as "The Tenderer" which expression shall include their successors, assignees and administrators) of the one part AND the Board of Trustees of Port of Cochin, Willingdon Island, Cochin-9, a Trust formed under "Major Port Trust Act 1963" represented by the Chief Mechanical Engineer (hereinafter referred to as "The Employer" which expression shall include their successors, assignees and administrators in the office) of the other part.

Whereas the "Employer" had called for the tenders for "-----" vide Tender Notice ----- dated----- and the tenderer had submitted a tender for the same giving the rates subject to the terms and conditions etc. And whereas the said tender of the tenderer has been accepted by the employer and a work order -----dated-----has been issued to the tenderer accepting their tender subject to the "General Conditions of Contract", "Instructions to the Tenderer" and such other contract documents. And as per one of the terms of the above work order, an agreement will have to be executed between the tenderer and the employer.

NOW THESE PRESENTS WITNESES AS FOLLOWS:

1. The tenderer hereby agrees to execute the work of "-----" as described in the schedule, its annexure etc. at the rates shown there under subject to the "General Conditions of Contract", 'Scope of work' and "Instructions to the Tenderer", all hereunto annexed within ----- from the date of handing over of the site or in default to forfeit and pay to the employer the sum of money mentioned in the said conditions.

The tenderer has furnished a Bank Guarantee for ----- (Rupees -----only) vide Bank Guarantee No.----- dated----- from, in lieu of Security Deposit for the due and proper fulfillment of the contract. The tenderer further agrees that the aforesaid Bank Guarantee will be kept valid until Two months beyond the expiry of the Guarantee Period. The tenderer also agrees that the Bank Guarantee furnished in lieu of Security Deposit for the due and proper fulfillment of the contract will be suitably enhanced so as to cover 10% cost of any additional items/ works that may be required for the proper completion of the contract or otherwise the employer can deduct such additional amounts towards Security Deposit from the Tenderer's bills.

The following documents shall be deemed to form and be read and construed as part of this agreement viz:

(List of relevant documents- will be furnished by Port)

The Conditions given in the work order dated -----shall over-ride the general conditions given in the tender document, wherever they differ. Any of the counter terms and

Cochin Port Trust
TENDER No.MD/PMW/ GHDNS GRAB REPAIRS /2020-22

44

conditions of the tenderer shall not be taken as terms and conditions of this contract/ agreement unless the Trustees in writing specifically agree to it.

IN WITNESS WHEREOF THE TENDERER hereunto set his hand and seal on behalf of And on behalf of the Board of Trustees of Port of Cochin, the Chief Mechanical Engineer has set his hand and seal and common seal of Trustees as has been hereunto affixed the day and year first written above.

Signed, sealed and delivered

by Shri. -----

of M/s -----

TENDERER

(COMMON SEAL OF THE FIRM)

Signed and affixed seal in the presence of:

Signature with address:

Signature with address:

Signed, sealed and delivered by

the Chief Mechanical Engineer,

Cochin Port Trust on behalf of

Board of Trustees of Port of Cochin.

EMPLOYER

Signed and affixed the common seal of Board of Trustees of the Port of Cochin in the presence of

1)

2)